



72" COUNTER DEPTH FRENCH DOOR REFRIGERATOR WITH INTERNAL DISPENSER

DETAILED PLANNING DIMENSIONS GUIDE

JFFCF72DKL – 35⁵/₈" (W) x 71" (H) x 30" (depth with handles)

PRODUCT DIMENSIONS

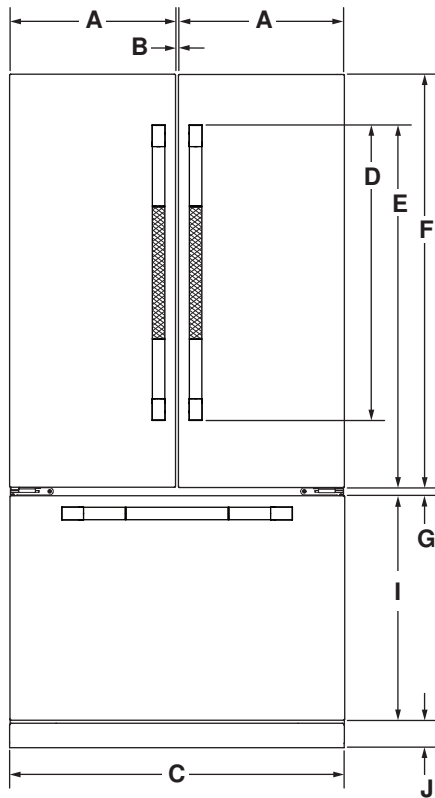

FRONT VIEW

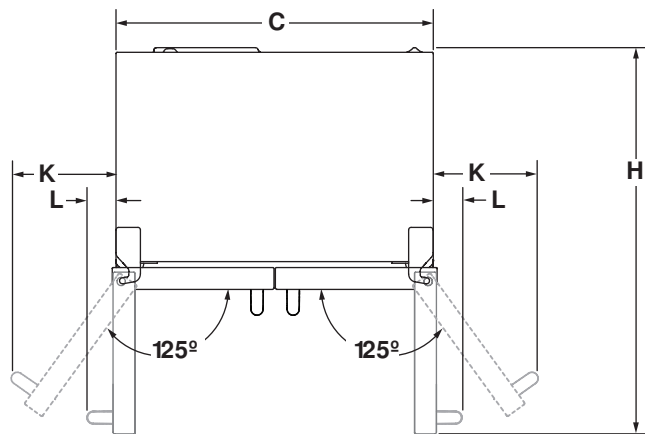

TOP VIEW

DIMENSION	DESCRIPTION	JFFCF72DKL
A	Width of each door	17" (44.8 cm)
B	Space between doors	3/8" (9 mm)
C	Overall width	35" (90.5 cm)
D	Height of door handles (RISE™)	32" (83.2 cm)
E	Height to top of door handles (RISE™)	38" (96.5 cm)
F	Height of doors	44" (112.1 cm)
G	Space between doors and drawer	1" (2.5 cm)
H	Depth with doors open 90°	44" (111.8 cm)
I	Height of drawer	23" (60.6 cm)
J	Height of grille	2" (7.3 cm)
K	Width from side of refrigerator to handle – door fully open 125° (RISE™)	11" (28 cm)
L	Width from side of refrigerator to handle – door open 90° (RISE™)	3" (8.6 cm)

Because Whirlpool Corporation policy includes a continuous commitment to improve our products, we reserve the right to change materials and specifications without notice.

Dimensions are for planning purposes only. For complete details, see Installation Instructions packed with product. Specifications subject to change without notice.



72" COUNTER DEPTH FRENCH DOOR REFRIGERATOR WITH INTERNAL DISPENSER

DETAILED PLANNING DIMENSIONS GUIDE

JFFCF72DKL – 35⁵/₈" (W) x 71" (H) x 30" (depth with handles)

PRODUCT DIMENSIONS CONT.

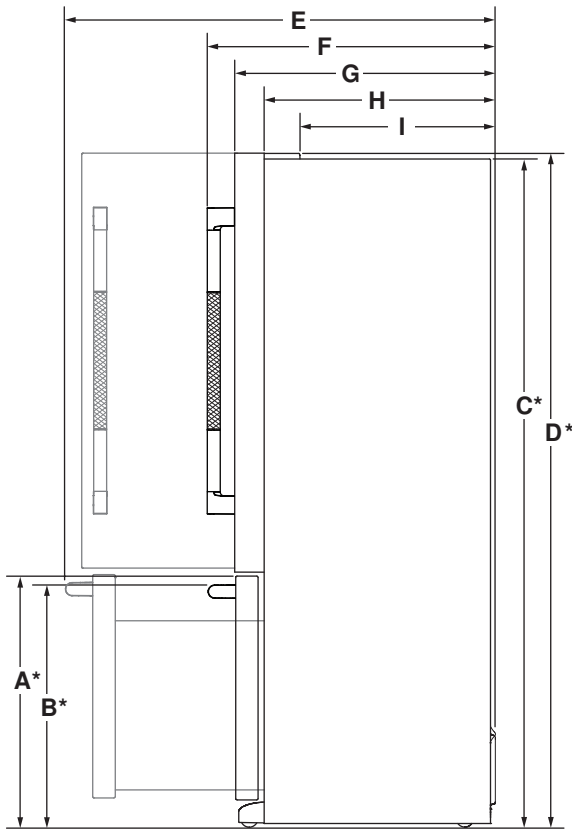

SIDE VIEW

DIMENSION	DESCRIPTION	JFFCF72DKL
A*	Height to top of drawer (m in.)	26 / " (67.9 cm)
B*	Height to top of drawer handle (m in.)	25 / " (65.4 cm)
C*	Height of recessed refrigerator (m in.)	71 / " (181 cm)
D*	Height to top of hinges (m in.)	71 / " (182.6 cm)
E	Depth with drawer fully open including drawer handle (m in.)	44 / " (112.5 cm)
F	Depth with handles (m in.)	30 / " (77.5 cm)
G	Depth with doors (m in.)	27 / " (70.2 cm)
H	Depth without doors (m in.)	24 / " (62.2 cm)
I	Depth to back of hinges (m in.)	20 / " (52.4 cm)

*Add 3/4" (1.9 cm) to the height dimension when leveling legs are fully extended.



72" COUNTER DEPTH FRENCH DOOR REFRIGERATOR WITH INTERNAL DISPENSER

DETAILED PLANNING DIMENSIONS GUIDE

JFFCF72DKL – 35⁵/₈" (W) x 71" (H) x 30" (depth with handles)

OPENING CLEARANCE DIMENSIONS

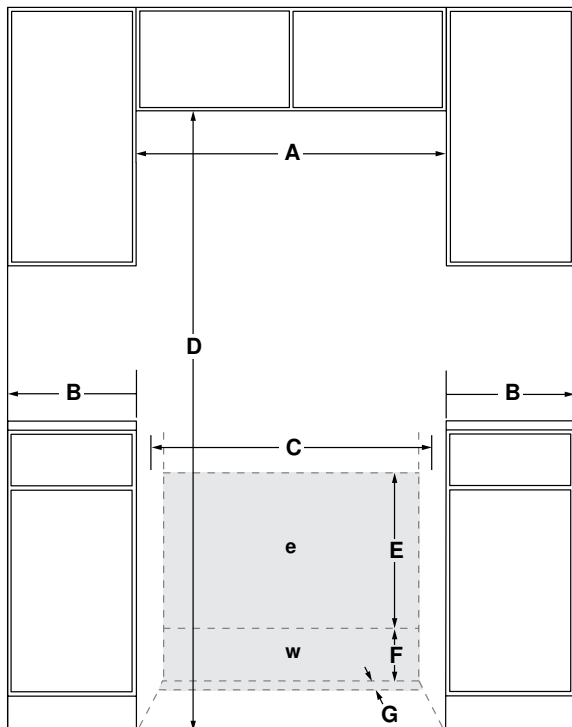

FRONT VIEW

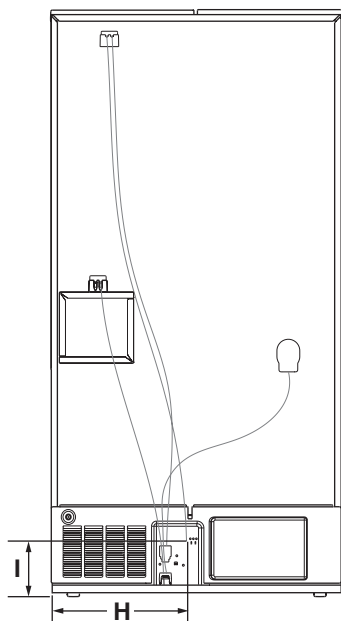

BACK VIEW

DIMENSION	DESCRIPTION	JFFCF72DKL
A	Width (min.)	36" (93 cm)
B	Minimum width from side of refrigerator to fixed wall – door open 90°	3" (8.6 cm)
	Minimum width from side of refrigerator to fixed wall – door open approx. 125°	11" (28 cm)
C	Width of recommended electrical/water installation area	34" (86.4 cm)
D	Height (min.)	71" (182.6 cm)
E	Height of recommended electrical installation area	10" (25.4 cm) Min. 24" (61 cm) Max.
F	Height of recommended water installation area	10" (25.4 cm)
G	Depth of recommended water installation area	1" (2.5 cm)
H	Water line location – distance from side	24" (62.5 cm)
I	Water line location – distance from bottom	9" (23.8 cm)
E	Recommended electrical connection location	
	Recommended water connection location	

Because Whirlpool Corporation policy includes a continuous commitment to improve our products, we reserve the right to change materials and specifications without notice.

Dimensions are for planning purposes only. For complete details, see Installation Instructions packed with product. Specifications subject to change without notice.

ELECTRICAL REQUIREMENTS

⚠ WARNING

Electrical Shock Hazard
Plug into a grounded 3 prong outlet.
Do not remove ground prong.
Do not use an adapter.
Do not use an extension cord.
Failure to follow these instructions can result in death, fire, or electrical shock.

A 115 V, 60 Hz, AC only 15 A or 20 A fused, grounded electrical supply is required. It is recommended that a separate circuit serving only your refrigerator and approved accessories be provided. Use an outlet that cannot be turned off by a switch. Do not use an extension cord.

WATER PRESSURE REQUIREMENTS

A cold water supply with water pressure of between 35 psi and 120 psi (241 kPa and 827 kPa) is required to operate the water dispenser and ice maker. If you have questions about your water pressure, call a licensed, qualified plumber.

Reverse Osmosis Water Supply

IMPORTANT: The pressure of the water coming out of a reverse osmosis system going to the water inlet valve of the refrigerator needs to be between 35 psi and 120 psi (241 kPa and 827 kPa).

If a reverse osmosis water filtration system is connected to the cold water supply, the water pressure to the reverse osmosis system needs to be a minimum of 40 psi to 60 psi (276 kPa to 414 kPa).

LOCATION REQUIREMENTS

⚠ WARNING

Explosion Hazard
Keep flammable materials and vapors, such as gasoline, away from refrigerator.
Failure to do so can result in death, explosion, or fire.

To ensure proper ventilation for your refrigerator, allow for 1/2" (1.25 cm) of space on each side and at the top. Allow for 1" (2.54 cm) of space behind the refrigerator.