

# KitchenAid®

## GRAIN MILL INSTRUCTIONS AND RECIPES



Model KGMA

This attachment has been approved for use with all KitchenAid® household stand mixers.



1-800-541-6390  
Details Inside



FOR THE WAY IT'S MADE.™

# Hassle-Free Replacement Warranty

---



We're so confident the quality of our products meets the exacting standards of KitchenAid that, if your Grain Mill should fail within the first year of ownership, KitchenAid will arrange to deliver an identical or comparable replacement to your door free of charge and arrange to have your "failed" Grain Mill returned to us. Your replacement unit will also be covered by our one-year full warranty. Please follow these instructions to receive this quality service.

**If you reside in the 50 United States** and your KitchenAid® Grain Mill should fail within the first year of ownership, simply call our toll-free Customer Satisfaction Center at **1-800-541-6390**, 8 a.m. to 8 p.m., Monday through Friday, 10 a.m. to 5 p.m., Saturday, Eastern Time. Give the consultant your complete shipping address. (No P.O. Box Numbers, please.)

When you receive your replacement Grain Mill, use the carton and packing materials to pack your "failed" Grain Mill. In the carton, include your name and address on a sheet of paper along with a copy of the proof of purchase (register receipt, credit card charge slip, etc.).

For a detailed explanation of warranty terms and conditions, including how to arrange for service outside the United States, see pages 3 and 4.

## Proof of Purchase and Product Registration

---

Always keep a copy of the sales receipt showing the date of purchase of your Grain Mill. Proof of purchase will assure you of in-warranty service. Before you use your Grain Mill, please fill out and mail your product registration card packed with the unit. This card will enable us to contact you in the unlikely event of a

product safety notification and assist us in complying with the provisions of the Consumer Product Safety Act. This card does not verify your warranty. Please complete the following for your personal records:

Model Number \_\_\_\_\_

Serial Number \_\_\_\_\_

Date Purchased \_\_\_\_\_

Store Name \_\_\_\_\_

# Table of Contents

Hassle-Free Replacement Warranty .....	Inside Front Cover
Product Registration Card .....	Inside Front Cover
Important Safeguards .....	2
Warranty .....	3
For the 50 United States and District of Columbia .....	3
For Puerto Rico .....	4
Arranging for Service After the Warranty Expires .....	4
Arranging for Service Outside the 50 United States and Puerto Rico .....	4
Ordering Accessories and Replacement Parts .....	4
Grain Mill Attachment .....	5
Assembling Your Grain Mill .....	5
Tips for Milling Grain .....	6
Suggested Grains .....	7
Using Your Grain Mill .....	8
Care and Cleaning .....	8
Recipes .....	9

## Your safety and the safety of others are very important.

We have provided many important safety messages in this manual and on your appliance. Always read and obey all safety messages.



This is the safety alert symbol.

This symbol alerts you to potential hazards that can kill or hurt you and others.

All safety messages will follow the safety alert symbol and either the word “DANGER” or “WARNING.” These words mean:



You can be killed or seriously injured if you don't immediately follow instructions.



You can be killed or seriously injured if you don't follow instructions.

All safety messages will tell you what the potential hazard is, tell you how to reduce the chance of injury, and tell you what can happen if the instructions are not followed.

# IMPORTANT SAFEGUARDS

---

When using electrical appliances, basic safety precautions should always be followed including the following:

1. Read all instructions.
2. To protect against risk of electrical shock, do not put mixer in water or other liquid.
3. Close supervision is necessary when any appliance is used by or near children.
4. Unplug mixer from outlet when not in use, before putting on or taking off parts and before cleaning.
5. Avoid contacting moving parts. Keep fingers out of discharge opening.
6. Do not operate the mixer with a damaged cord or plug or after the mixer malfunctions, or is dropped or damaged in any manner. Return the mixer to the nearest Authorized Service Center for examination, repair or electrical or mechanical adjustment.
7. The use of attachments not recommended or sold by KitchenAid may cause fire, electric shock or injury.
8. Do not use the mixer outdoors.
9. Do not let the cord hang over the edge of table or counter.
10. Do not let cord contact hot surface, including the stove.
11. Check hopper for presence of foreign objects before using.
12. This attachment should not be operated by children and the unit should be out of reach of children during operation.
13. This product is designed for household use only.

## SAVE THESE INSTRUCTIONS

# KitchenAid® Grain Mill Attachment Warranty for the 50 United States and District of Columbia

This warranty extends to the purchaser and any succeeding owner for Grain Mills operated in the 50 United States and District of Columbia.

Length of Warranty:	KitchenAid Will Pay For Your Choice of:	KitchenAid Will Not Pay For:
<p>One Year Full Warranty from date of purchase.</p>	<div style="text-align: center;">  </div> <p>Hassle-Free Replacement of your Grain Mill. See inside front cover for details on how to arrange for service, or call the Customer Satisfaction Center toll-free at <b>1-800-541-6390</b>.</p> <p style="text-align: center;">OR</p> <p>The replacement parts and repair labor costs to correct defects in materials and workmanship. Service must be provided by an Authorized KitchenAid Service Center. See the KitchenAid® Grain Mill Warranty for Puerto Rico on page 4 for details on how to arrange for service.</p>	<ul style="list-style-type: none"> <li>A. Repairs when Grain Mill is used in other than normal single family home use.</li> <li>B. Damage resulting from accident, alteration, misuse or abuse.</li> <li>C. Any shipping or handling costs to deliver your Grain Mill to an Authorized Service Center.</li> <li>D. Replacement parts or repair labor costs for Grain Mill operated outside the 50 United States and District of Columbia.</li> </ul>

**KITCHENAID DOES NOT ASSUME ANY RESPONSIBILITY FOR INCIDENTAL OR CONSEQUENTIAL DAMAGES.** Some states do not allow the exclusion or limitation of incidental or consequential damages, so this exclusion may not apply to you. This warranty gives you specific legal rights and you may also have other rights which vary from state to state.

# KitchenAid® Grain Mill Warranty for Puerto Rico

---

A limited one-year warranty extends to the purchaser and any succeeding owner for Grain Mills operated in Puerto Rico. During the warranty period, all service must be handled by an Authorized KitchenAid Service Center. Please bring the Grain Mill, or ship it prepaid and insured, to the

nearest Authorized Service Center. Call toll-free **1-800-541-6390** to learn the location of a Service Center near you. Your repaired Grain Mill will be returned to you prepaid and insured.

## Arranging for Service After the Warranty Expires

---

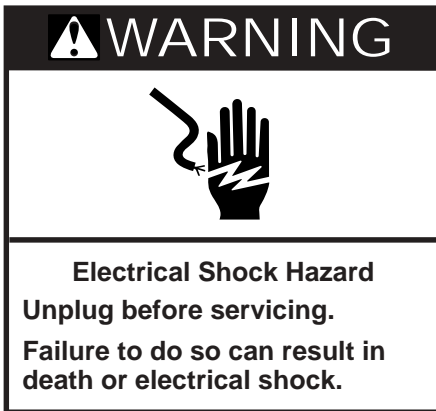

For service information, call toll-free **1-800-541-6390** or write to: Customer Satisfaction Center, KitchenAid Portable Appliances, P.O. Box 218, St. Joseph, MI 49085-0218.

## Arranging for Service Outside the 50 United States and Puerto Rico

---

Consult your local KitchenAid dealer or the store where you purchased the

Grain Mill for information on how to obtain service.

## Ordering Accessories and Replacement Parts

---

To order accessories or replacement parts for your Grain Mill, call toll-free **1-800-541-6390** or write to:

Customer Satisfaction Center, KitchenAid Portable Appliances, P.O. Box 218, St. Joseph, MI 49085-0218.

# Grain Mill Attachment

The following attachment is designed to mill low-moisture, non-oily grains such as wheat, corn, rye, oats, rice, buckwheat, barley, and millet.

**Grain Mill Body** — serves as a hopper; guides grains into grinding burr

**Grind Worm** — drives grinding action

**Movable Burr** — grinds whole grains into flour

**Adjustment Knob** — adjusts the fineness of the grind

**Cleaning Brush** — use to clean burrs and other mill parts after use.

**NOTE:** Never immerse Grain Mill in water or other liquid. Never wash in dishwasher. For recommended cleaning methods, See Care and Cleaning section on page 8.

**NOTE:** The Grain Mill is designed to grind only low-moisture, non-oily grains. Do not grind peanuts, coffee beans, soybeans, or sunflower seeds with the Grain Mill; their high oil or high-moisture contents can damage the grinding mechanism.

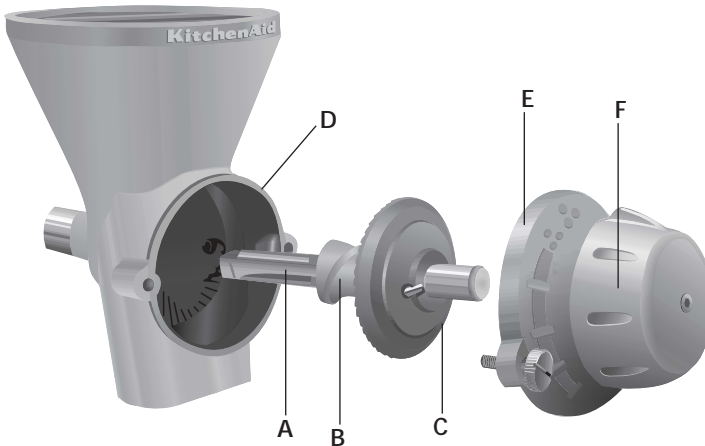

## Assembling Your Grain Mill

**NOTE:** The grinding burrs of this unit have been lightly coated with mineral oil to help prevent rusting during storage. Before using the grain mill, wash off the oil with a mild detergent solution and dry thoroughly. If you do not remove the oil, the burrs will become clogged and the grinding action will slow down. After using the grain mill, follow the “Care and Cleaning” section on page 8.

### TO ASSEMBLE:

Insert the attachment power shaft (A) with the grind worm (B) and movable burr (C) into the grain mill body (D). Mount the front plate (E) with adjustment knob (F) onto the front of the shaft. Turn and tighten screws into place.

# Assembling Your Grain Mill

---

## TO ASSEMBLE:

Insert the attachment power shaft (A) with the grind worm (B) and movable burr (C) into the grain mill body (D). Mount the front plate (E) with adjustment knob (F) onto the front of the shaft. Turn and tighten screws into place.

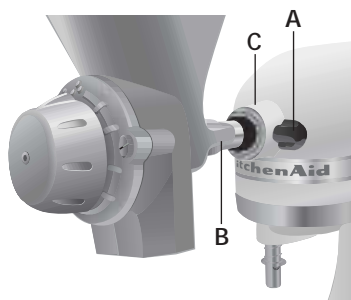

## TO ATTACH:

Before attaching the grain mill, turn off and unplug the stand mixer.

1. Depending on which type of hub you have, either flip up the hinged cover or loosen the attachment knob (A) by turning it counterclockwise and remove attachment hub cover.

2. Insert the attachment shaft housing (B) into the attachment hub (C), making certain that the power shaft fits into the square hub socket. Rotate the attachment back and forth if necessary. When the attachment is in proper position, the

## Tips for Milling Grain

---

Flour ground with the Grain Mill will have a coarser texture than commercially ground flour. The Grain Mill grinds, and you receive, all parts of the berry; commercial grinders sift out some parts of the berry before marketing the flour.

It is not necessary to press grain into the Grain Mill hopper with your hands or any utensil. The moving grind worm will feed the grain into the grinding burrs.

One cup of grain yields between 1¼ and 1½ cups of flour.

One cup of oats yield ⅔ cup of flour.

If you grind more flour than your recipe requires, store it in the refrigerator or freezer to prevent rancidity, since this product contains no preservatives.

Do not grind coffee beans in your Grain Mill; their high oil content can damage the grinding mechanism.

Do not grind grains or nuts with a high moisture or oil content, such as peanuts, sunflower seed, and soybeans. These can also damage the grinding mechanism.



# Suggested Grains

---

All these low-moisture, non-oily grains may be ground in your KitchenAid® Grain Mill:

**WHEAT** — Many different types of wheat are grown in the United States. Hard wheat, with a high percentage of protein, is generally considered best for bread flour; soft wheats are preferred for cakes, cookies, and other baked goods. Mix hard and soft wheats for all-purpose flour.

**CORN** — Grind fine for baking, coarse for corn meal mush.

**RYE** — Combine rye flour with wheat flour for best results with rye bread; rye does not contain enough gluten for good rising.

**OATS** — Oats must be hulled before grinding for flour, or use rolled oats. Oat hulls prevent proper feeding of grain into grinding burrs. In most recipes you can substitute oat flour for up to  $\frac{1}{3}$  of the all-purpose flour.

**RICE** — Both white and brown rice grind well.

**BUCKWHEAT** — For best results, buckwheat should be hulled before grinding. Raw and toasted buckwheat both grind well.

**BARLEY** — For best results, barley should be hulled before grinding.

**MILLET** — Before grinding, toast millet in a heavy, dry skillet to bring out this very small grain's unique flavor. Stir constantly to prevent burning.

Your local library or health food store can provide more information on grains.

# Using Your Grain Mill

---

## TO USE:

Note the grind symbols at the top of the dial. The Fine Grind Symbol (A) indicates the finest grind setting. The Coarse Grind Symbol (B) indicates the setting for the grind that is most coarse. Each notch on the dial represents a grind setting.

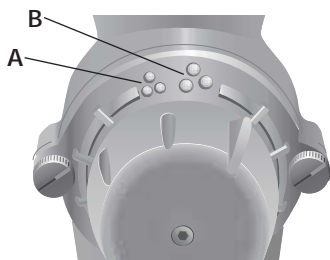

1. Select the finest grind setting by turning the adjustment knob (C) clockwise to the Fine Grind Symbol (A).

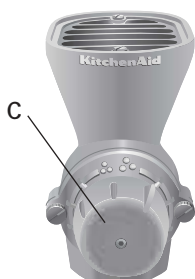

2. Fill the hopper with grain.
3. Once the grain is added, start the mixer at Speed 10.

**NOTE:** If the grind is too fine, turn the adjustment knob counterclockwise, one notch at a time, until desired coarseness is obtained.

4. Continue to replenish grain in the hopper until the desired amount of grain is ground.

**NOTE:** Do not grind more than 10 cups of flour at one time; damage to mixer may result. After grinding 10 cups of flour, allow the mixer to cool at least 45 minutes before using it again.

---

## Care and Cleaning

---

### TO CLEAN:

Clean burrs and other mill parts with the provided brush. The Mill does not necessarily need to be cleaned after every use, but should be brushed when changing types of grains. If needed, a toothpick may be used to clean the burr grooves.

**IMPORTANT:** Do not wash Grain Mill or any of its parts in an automatic dishwasher.

If the Grain Mill must be washed, wash it by hand with mild detergent and warm water. Dry thoroughly with a towel. Allow to air dry. Do not reassemble until next use. If burrs are not completely dry, grain may clog the mill.

If the unit is to be stored for a long period of time, lightly coat the burrs with mineral oil. Before next use, hand wash as directed above to remove the mineral oil.

## Jalapeño Corn Muffins

- 1 cup corn or 1½ cups cornmeal
- ¾ cup wheat berries or 1 cup whole wheat flour
- 1 tablespoon baking powder
- ½ teaspoon salt
- 1 cup low-fat milk
- ¼ cup oil
- 3 tablespoons honey
- 1 egg
- 2 tablespoons canned diced jalapeño peppers

Assemble the Grain Mill and attach to the mixer. Set the mill on the finest setting. Turn the mixer to Speed 10 and grind corn into the mixer bowl placed under the mill. Repeat with wheat berries.

Add baking powder and salt to the mixer bowl; mix well. Add all remaining ingredients. Attach the bowl and flat beater to the mixer. Turn the mixer to Stir Speed and mix about 15 seconds. Stop and scrape the bowl. Turn the mixer to Stir Speed and mix about 15 seconds.

Spoon the batter into greased muffin pans. (Do not use cupcake liners.) Bake at 400° F for 15 to 18 minutes, or until toothpick inserted into center comes out clean. Remove from pans immediately. Serve warm.

Yield: 12 servings (1 muffin per serving).

Per serving: About 121 cal, 3 g pro, 16 g carb, 6 g fat, 19 mg chol, 191 mg sod.

## Honey Whole-Wheat Pancakes

- 1 cup wheat berries or 1½ cups whole wheat flour
- 1 teaspoon baking soda
- ¼ teaspoon salt
- ¼ teaspoon nutmeg
- 1½ cups buttermilk
- ½ cup fat-free egg substitute or 2 eggs
- 3 tablespoons honey

Assemble the Grain Mill and attach to the mixer. Set the mill on the finest setting. Turn the mixer to Speed 10 and grind the wheat berries into the mixer bowl placed under the mill.

Add baking soda, salt, and nutmeg to the mixer bowl; mix well. Add all remaining ingredients. Attach the bowl and flat beater to the mixer. Turn the mixer to Speed 2 and mix about 15 seconds. Stop and scrape the bowl. Turn the mixer to Speed 2 and mix about 15 seconds, or until smooth.

Spray griddle or heavy skillet with no-stick cooking spray. Heat the griddle to medium-high heat. Pour about ½ cup batter for each pancake onto the griddle. Cook 1 to 2 minutes, or until bubbles form on the surface and the edges become dry. Turn and cook about 1 to 2 minutes longer, or until golden brown on the underside.

Yield: 6 servings (2 pancakes per serving).

Per serving: About 170 cal, 9 g pro, 34 g carb, 1 g fat, 2 mg chol, 402 mg sod.



FOR THE WAY IT'S MADE.™

® Registered trademark/™ Trademark/  
the shape of the mixer is a trademark of KitchenAid, U.S.A.