

NOTE: This sheet contains important Technical Service Data.
FOR SERVICE TECHNICIAN ONLY
DO NOT REMOVE OR DESTROY

FOR SERVICE TECHNICIAN'S USE ONLY

Wiring Diagram

Do Not Remove Or Destroy

Quick Connect Plugs

For oven controls

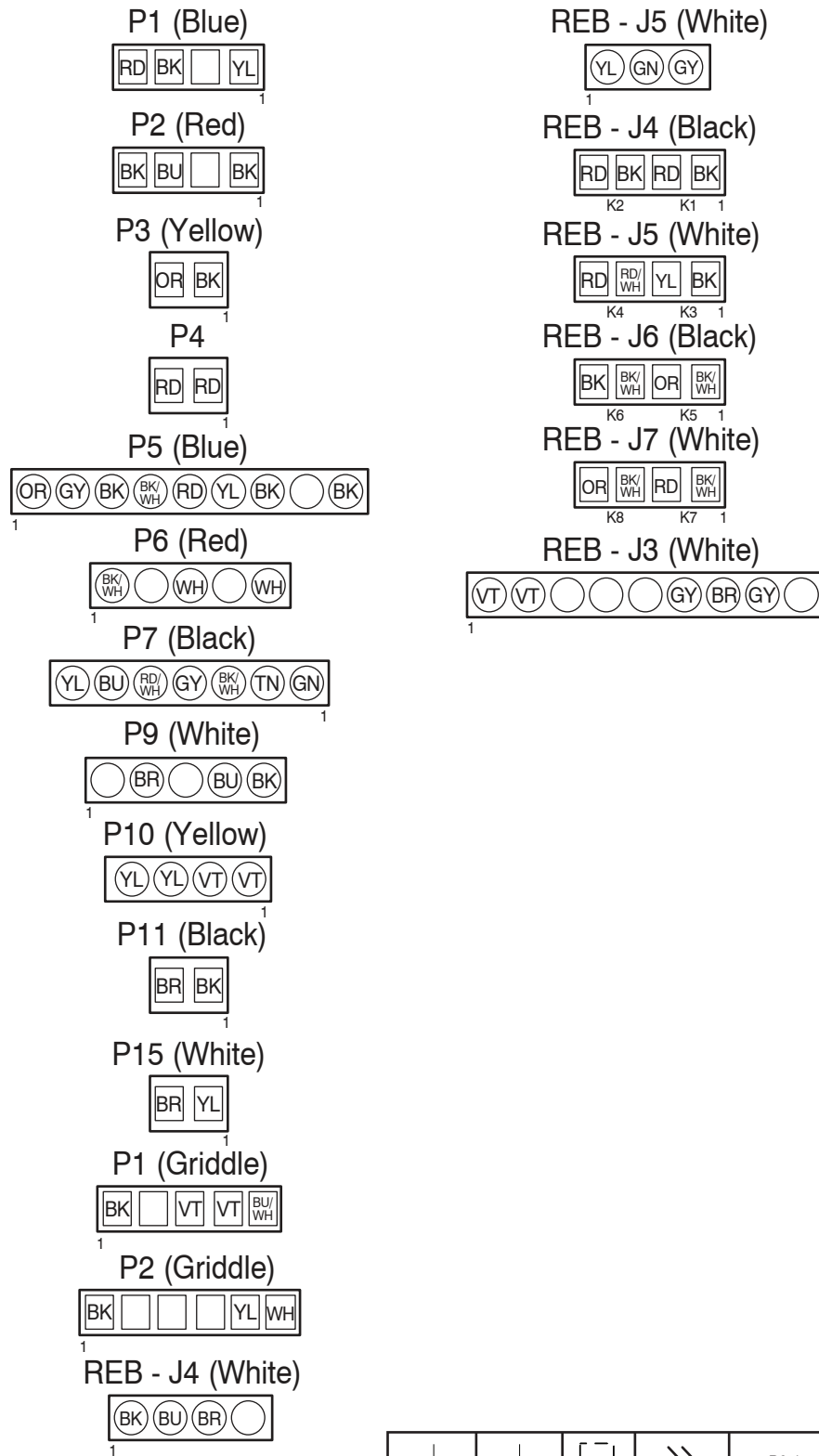

Oven Control Wiring Diagram

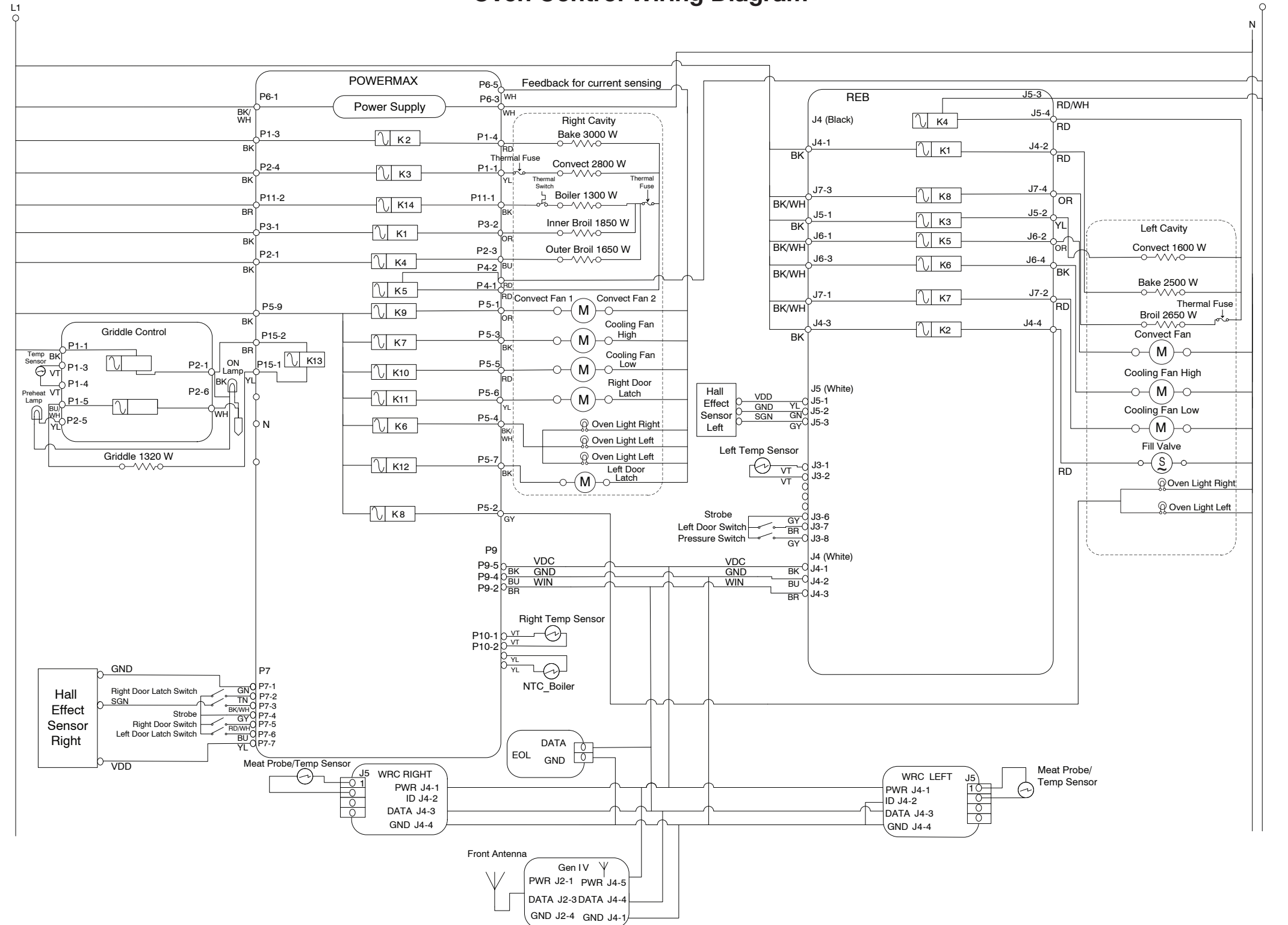

LEGEND

Connection	No Connection	On Some Models	In-Line Connection	Connector P2, Position 1	Circuitry Enclosed Within	Terminals	Single Switch	Thermal Switch (opens on heat rise)	Thermal Switch (closes on heat rise)	Resistor or Element	Motor	Incandescent Light	Non-resettable Fuse	Thermistor	Indicator Light	Triac	Thermo Fuse	Temp Sensor	Fill Valve

Fiches à connexion rapide

Pour les commandes du four

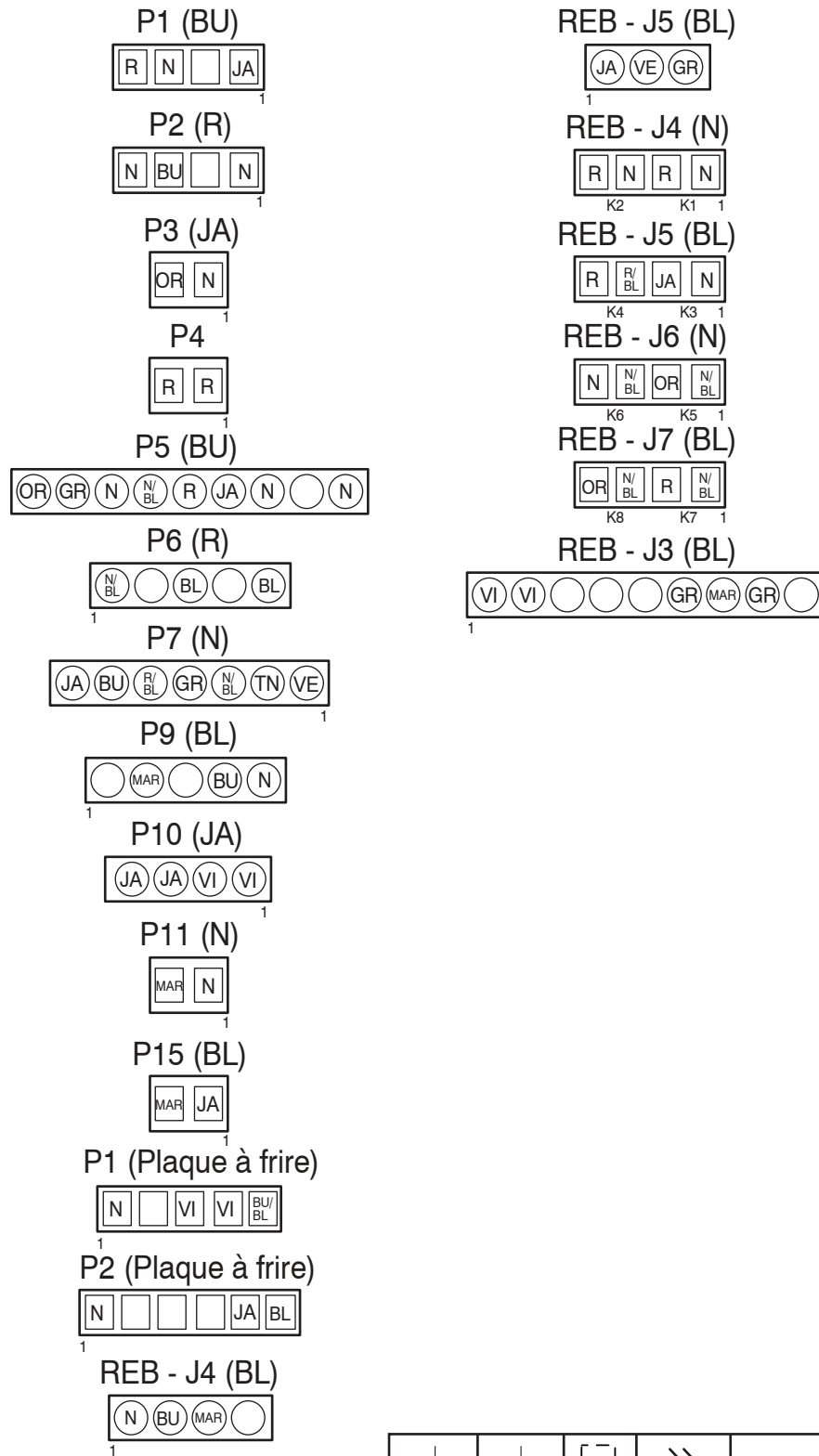

Schéma de câblage du module de commande du four

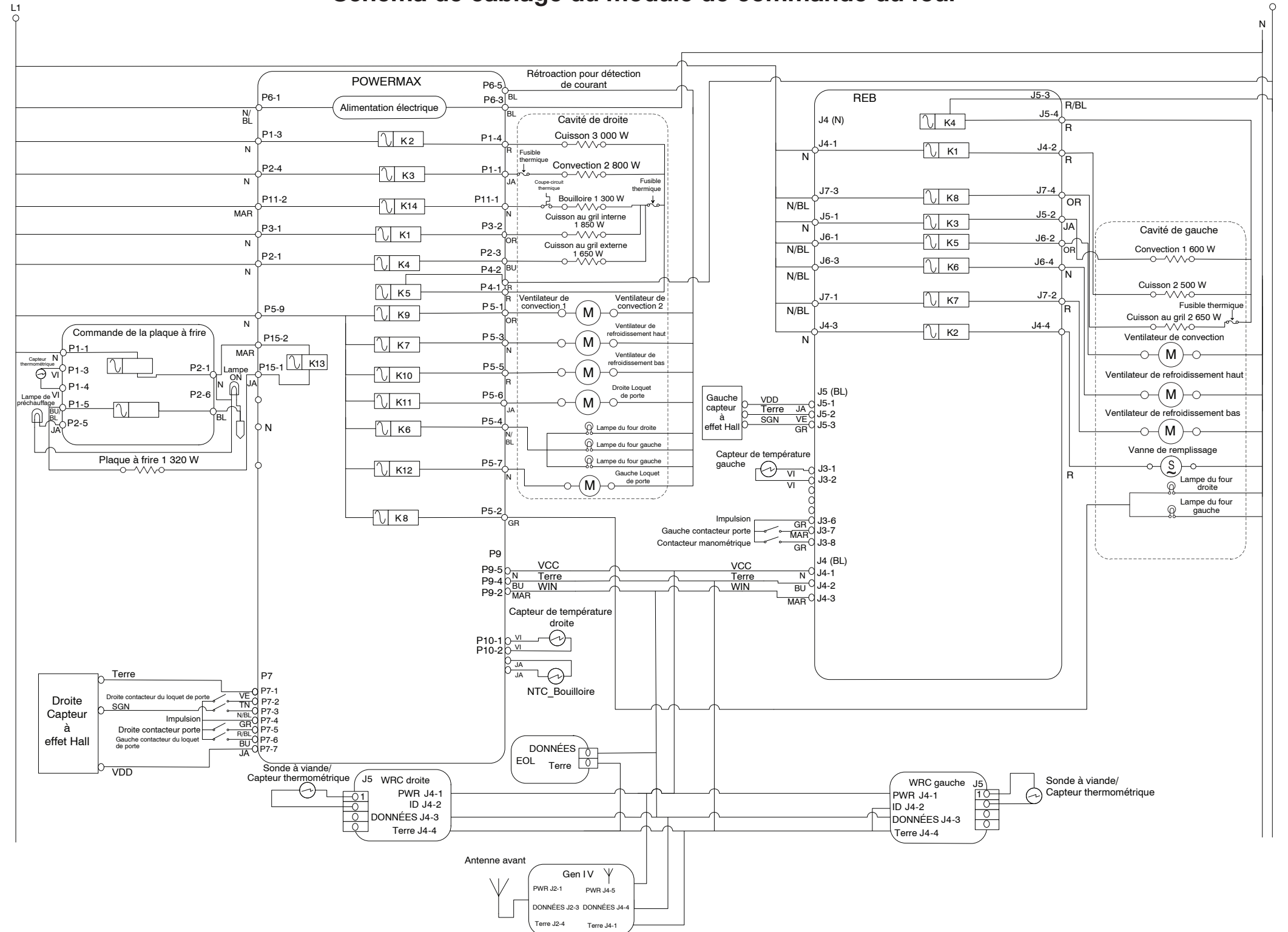

LÉGENDE

Connexion	Pas de connexion	Sur certains modèles	Connexion en série	P2-1	Circuit à l'intérieur	Broches du composant	Contacteur simple	Commutateur thermique (s'ouvre lorsque la chaleur augmente)	Commutateur thermique (se ferme lorsque la chaleur augmente)	Résistance ou élément	Moteur	Lampe à incandescence	Fusible non réarmable	Thermistance	Témoin lumineux	Triac	Fusible thermique	Capteur de température	Vanne de remplissage