

DETAILED PLANNING DIMENSIONS

15" ICE MACHINES

WUI75X15H/ WUI95X15H– D 24" x W 14⁵/₈" x H 33⁴⁹/₆₄" (depth without handle)

PRODUCT DIMENSIONS

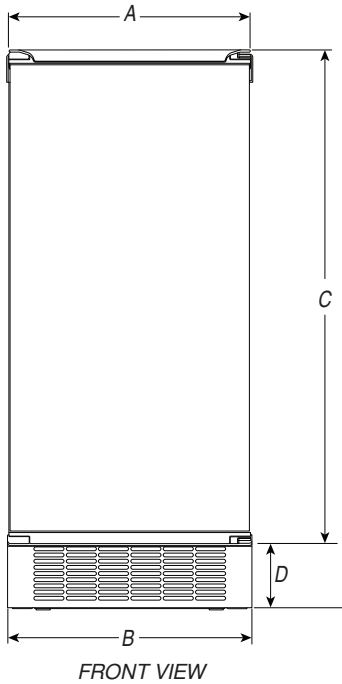

MODEL #		WUI75X15H, WUI95X15H	
		in	cm
A	Width	14 ⁵ / ₈	37.15
B	Width of grille	14 ²⁵ / ₃₂	37.55
C	Height of door	29 ⁵⁵ / ₆₄	75.85
D	Height of grille	3 ²⁹ / ₃₂	9.95
E	Width of recessed ice machine	14 ²⁹ / ₃₂	37.81
F	Width from side of ice machine to door fully open	5 ⁷ / ₈	14.94
G	Depth without door	21 ²¹ / ₃₂	55.02
H	Depth with door	23 ¹³ / ₃₂	59.46
I	Depth with handle	24 ⁹ / ₁₆	62.42

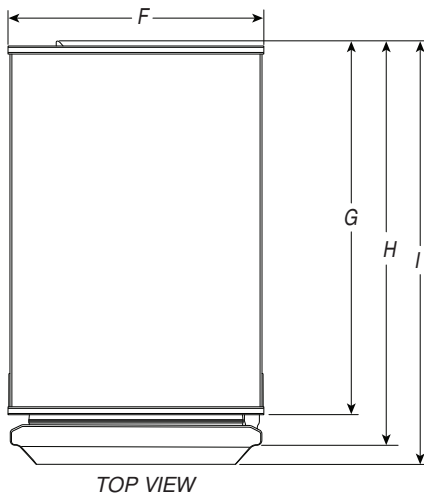

IMPORTANT: Dimensional specifications are provided for planning purposes only. Do not make any cutouts based on this information. Refer to the Installation or Use & Care Guide before selecting cabinetry, verifying electrical/gas connections, making cutouts or beginning installation. All Whirlpool® appliances are appropriately UL, CUL or CSA approved.



DETAILED PLANNING DIMENSIONS

15" ICE MACHINES

WUI75X15H/ WUI95X15H– D 24" x W 14⁵/₈" x H 33⁴⁹/₆₄" (depth without handle)

	MODEL #	WUI75X15H, WUI95X15H	
		in	cm
A*	Height to top of door (min.)	33 ⁷ / ₈	86.03
B*	Height to top of grille (min.)	3 ²⁹ / ₃₂	9.95
C*	Height of recessed ice machine (min.)	33 ²⁹ / ₆₄	85.38
D	Depth with door open 90° (min.)	37 ³ / ₈	94.92
E	Depth with door (min.)	23 ¹³ / ₃₂	59.46
F	Depth without door (min.)	21 ⁹ / ₁₆	54.76
G	Depth of grille (min.)	19 ⁶³ / ₆₄	50.76

* Add 1" (2.5 cm) to the height dimension when leveling legs are fully extended.

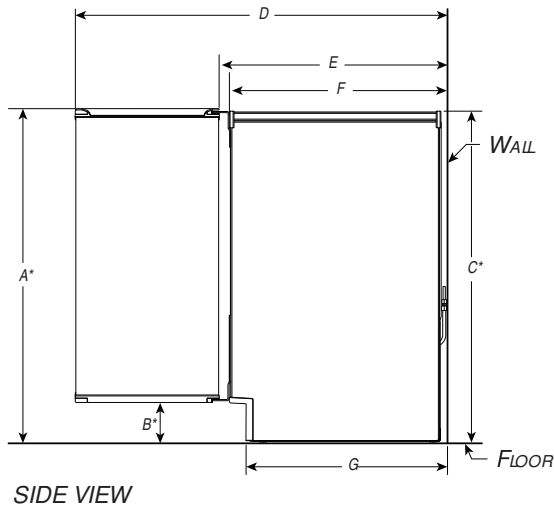

IMPORTANT: Dimensional specifications are provided for planning purposes only. Do not make any cutouts based on this information. Refer to the Installation or Use & Care Guide before selecting cabinetry, verifying electrical/gas connections, making cutouts or beginning installation. All Whirlpool® appliances are appropriately UL, CUL or CSA approved.



In some European factories the letter "W" of the part code mentioned herein will be automatically replaced by the number "4000" (e.g. "W12345678" becomes "400012345678")

DETAILED PLANNING DIMENSIONS

15" ICE MACHINES

WUI75X15H/ WUI95X15H– D 24" x W 14⁵/₈" x H 33⁴⁹/₆₄" (depth without handle)

OPENING/CLEARANCE DIMENSIONS

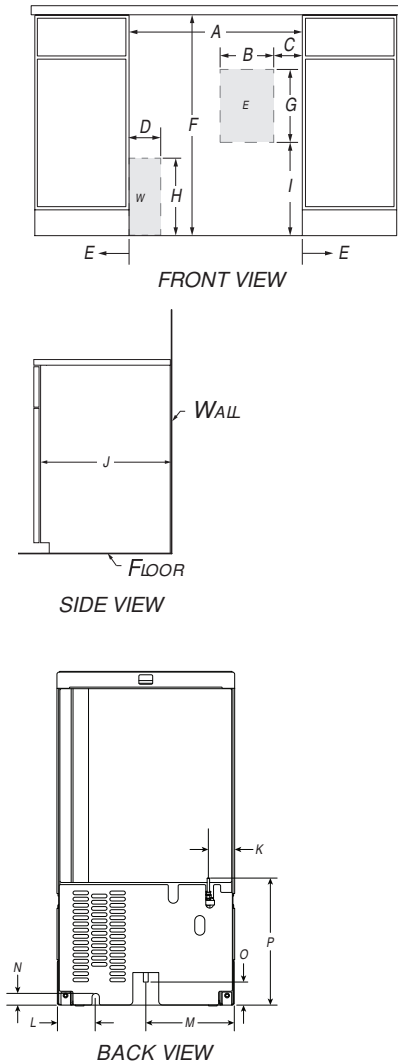

MODEL #		WUI75X15H, WUI95X15H	
		in	cm
A*	Width (min.)	15	38.1
	Width without hinge side spacer option (min.)	15	38.1
	Width with hinge side spacer option (min.)	15 ³ / ₄	40.0*
B*	Width of outlet location	6	15.0
C*	Outlet location – distance from side	1	2.5
D*	Width of water connection location	3 ¹ / ₂	8.9
E	Minimum width from hinged side of ice machine to fixed wall – door open 90°	2	5.1
	Minimum width from hinged side of ice machine to fixed wall – door fully open 180°	13 ¹ / ₄	33.7
	Minimum width from hinged side of ice machine to fixed wall – door fully open 118°	6 ⁷ / ₈	17.4
F	Height (min.)	34	86.4
G	Height of outlet location	8	20.3
H	Height of water connection location	9	22.9
I	Outlet location – distance from bottom	12	30.5
J	Depth of cabinet (min.)	24	61.0
K	Water line location – distance from side	2 ³⁹ / ₆₄	6.64
L	Power supply – distance from side	3 ⁴⁹ / ₆₄	9.57
M	Drain hose – distance from side	7 ⁵ / ₁₆	18.57
N	Power supply – distance from bottom	1 ¹ / ₄	3.17
O	Drain hose – distance from bottom	2 ⁴³ / ₆₄	6.79
P	Water line location – distance from bottom	14 ⁷ / ₃₂	36.12
e	Recommended electrical connection location		
w	Recommended water connection location		

* Install 3/4" (1.9 cm) front hinge-side spacer flush with face of adjacent cabinet and 3/4" (1.9 cm) back hinge-side spacer 6" (15.2 cm) from back wall.

ELECTRICAL REQUIREMENTS

115 V, 60 Hz, AC only, 15 or 20 A fused, grounded circuit is required. A dedicated circuit is recommended. Use an outlet that cannot be turned off by a switch. Do not use an extension cord.

WATER PRESSURE REQUIREMENTS

A cold water supply with water pressure between 30 and 120 psi (207 and 827 kPa) is required to operate the ice maker. Call a licensed, qualified plumber with any questions about the water pressure.

Reverse Osmosis Water Supply

IMPORTANT: The use of a reverse osmosis system with this product is not recommended. However if you do use reverse osmosis, follow these instructions.

IMPORTANT: The pressure of the water coming out of a reverse osmosis system going to the water inlet valve of the ice machine needs to be between 30 and 120 psi (207 and 827 kPa). If a reverse osmosis water filtration system is connected to the cold water supply, the water pressure to the reverse osmosis system needs to be a minimum of 40 to 60 psi (276 to 414 kPa).

IMPORTANT: Dimensional specifications are provided for planning purposes only.

Do not make any cutouts based on this information. Refer to the Installation or Use & Care Guide before selecting cabinetry, verifying electrical/gas connections, making cutouts or beginning installation. All Whirlpool® appliances are appropriately UL, CUL or CSA approved.



W11349808A

®/™ ©2019 Whirlpool. All rights reserved.

03/19

In some European factories the letter "W" of the part code mentioned herein will be automatically replaced by the number "4000" (e.g. "W12345678" becomes "400012345678")