

FOR SERVICE TECHNICIAN'S USE ONLY

Wiring Diagram

Do Not Remove Or Destroy

Quick Connect Plugs

For oven controls

P1 (Red)

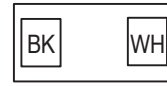

P2 (Blue)

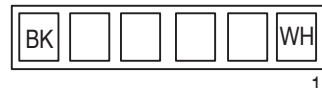

P3 (Red)

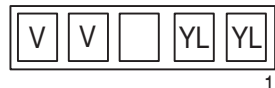

P4 (Red)

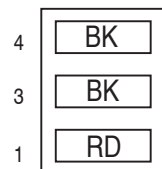

P5 (Blue)



P10 (Yellow)

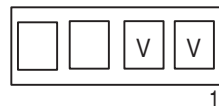

Oven Control Wiring Diagram

NOTE: Schematic shows elements off.

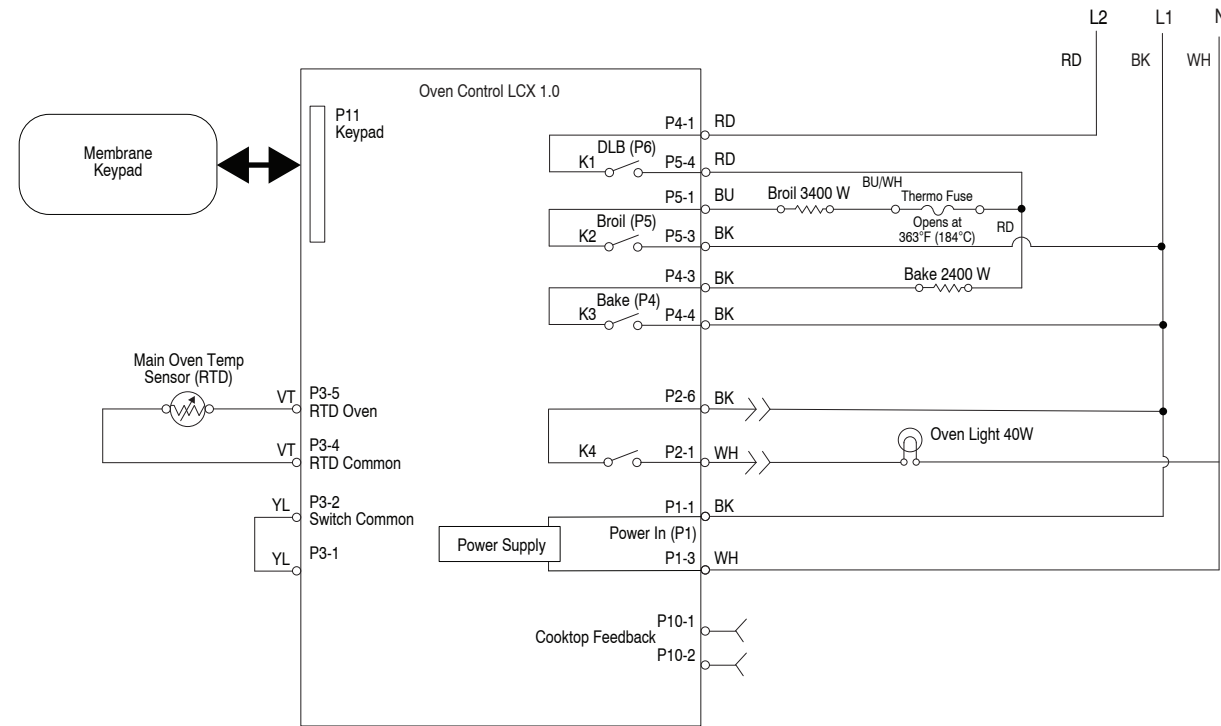

Cooktop Wiring Diagram

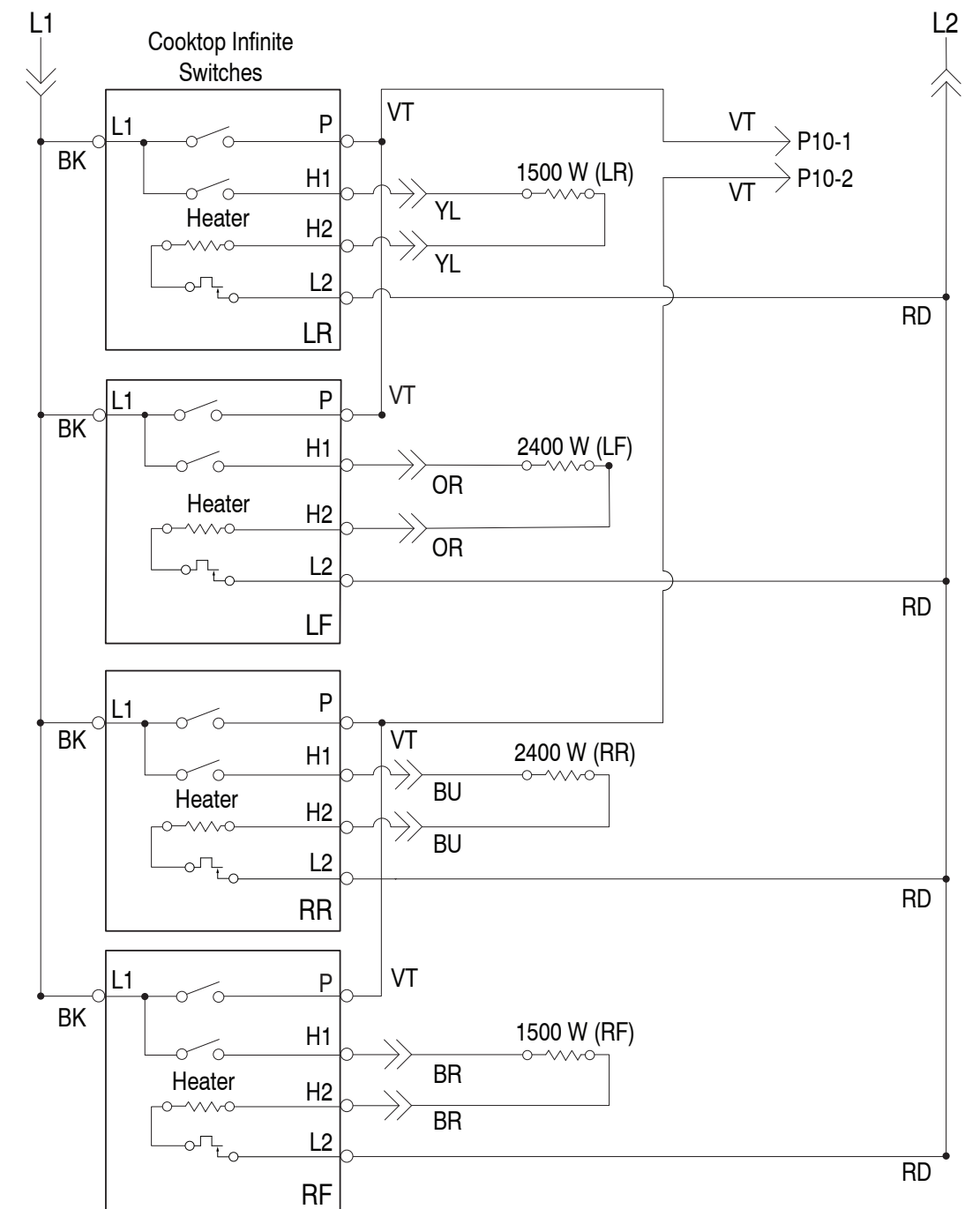

LEGEND

Connection	No Connection	On Some Models	In-Line Connection	Connector P2, Position 1	Circuitry Enclosed Within	Terminals	Single Switch	Thermal Switch (opens on heat rise)	Thermal Switch (closes on heat rise)	Resistor or Element	Motor	Incandescent Light	Non-resettable Fuse	Thermistor	Indicator Light	Triac	Thermo Fuse

À L'USAGE DU TECHNICIEN DE RÉPARATION UNIQUEMENT

Schéma de câblage

Ne pas enlever ou détruire

Fiches à connexion rapide

Pour modules de commande du four



Schéma de câblage du module de commande du four

REMARQUE : Le schéma représente les éléments non alimentés.



Schéma de câblage de la table de cuisson

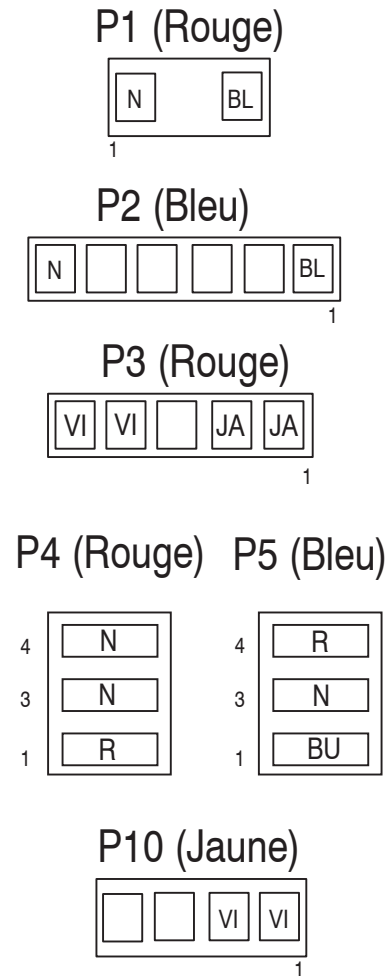
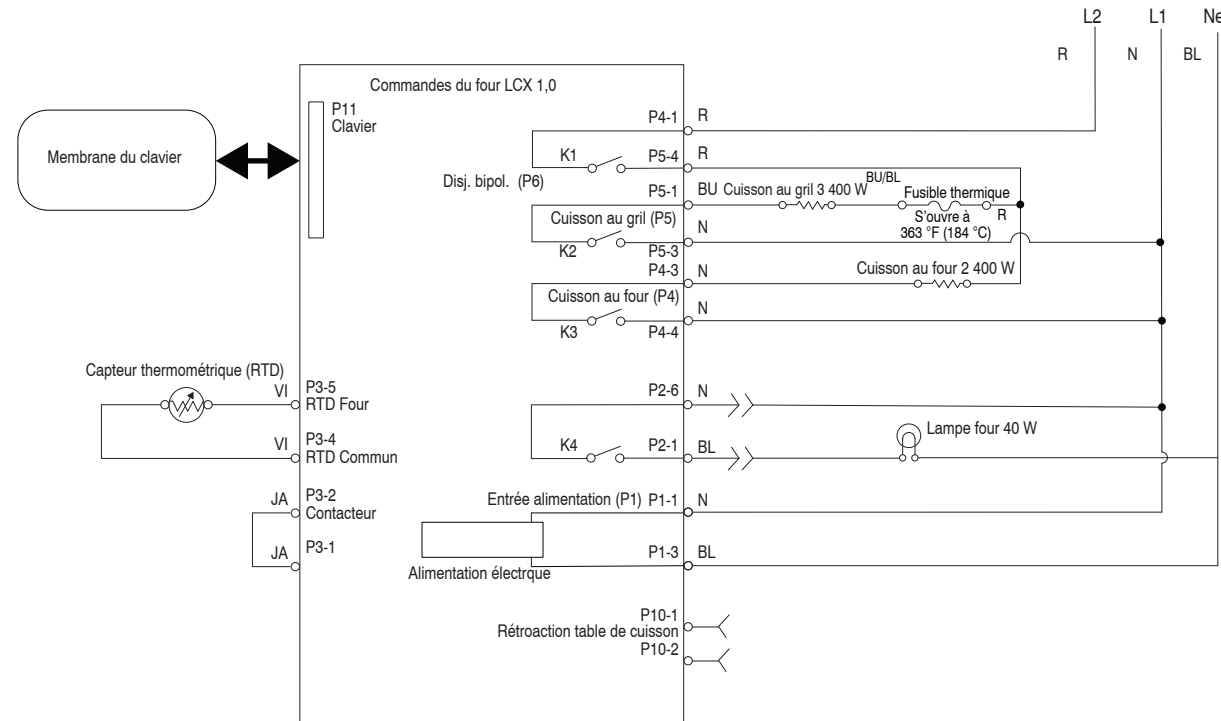
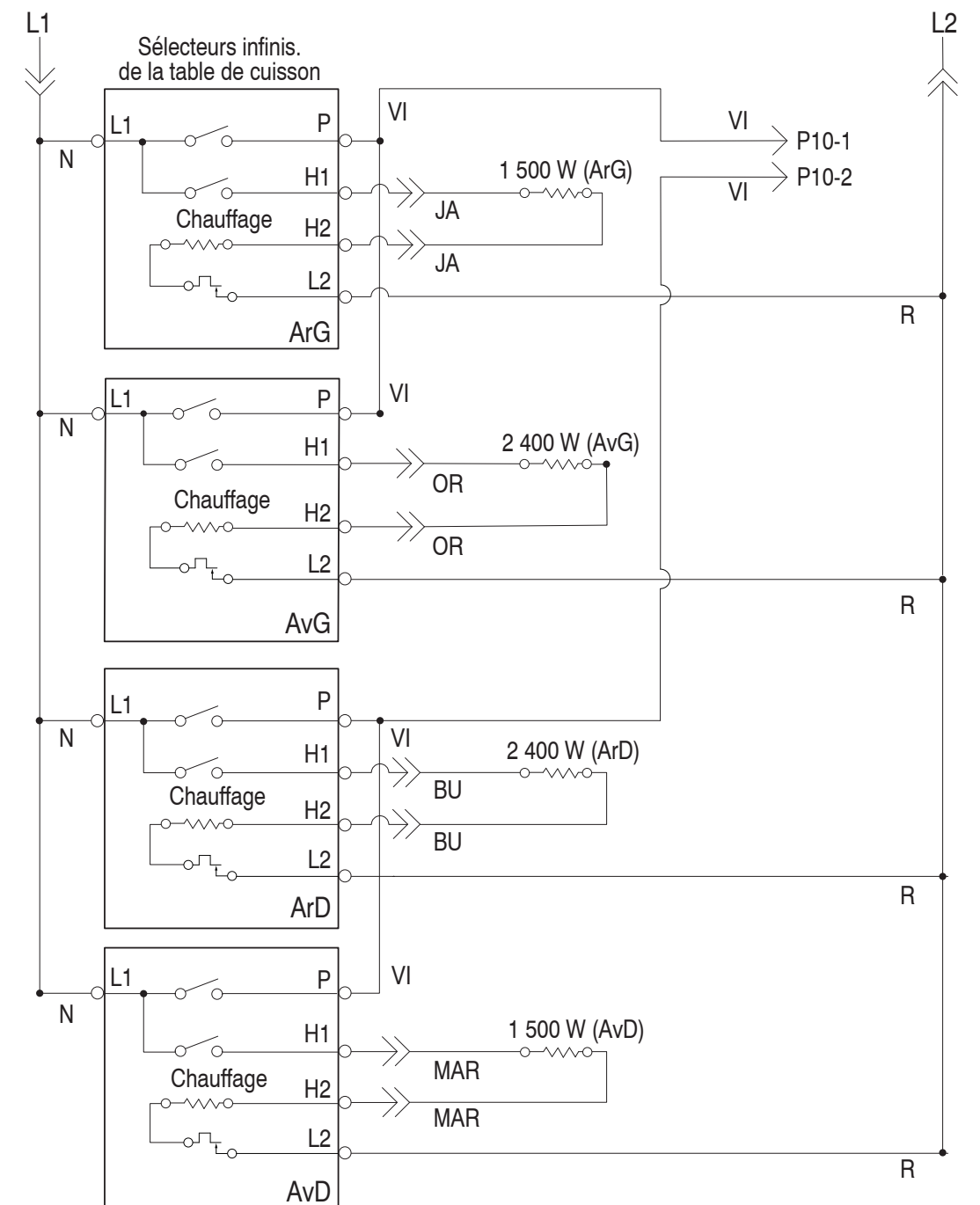

LÉGENDE

Connexion	Pas de connexion	Sur certains modèles	Connexion en série	Connecteur P2 Position 1	Circuit fonctionnel à l'intérieur	Broches du composant	Contacteur simple	Coupe-circuit thermique (ouvre lorsque la chaleur augmente)	Coupe-circuit thermique (ferme lorsque la chaleur augmente)	Résistance ou élément	Moteur	Lampe à incandescence	Fusible non réarmable	Thermistance	Témoin lumineux	Triac	Fusible thermique