

FOR SERVICE TECHNICIAN'S USE ONLY

Wiring Diagram

Do Not Remove Or Destroy

Quick Connect Plugs

For oven controls

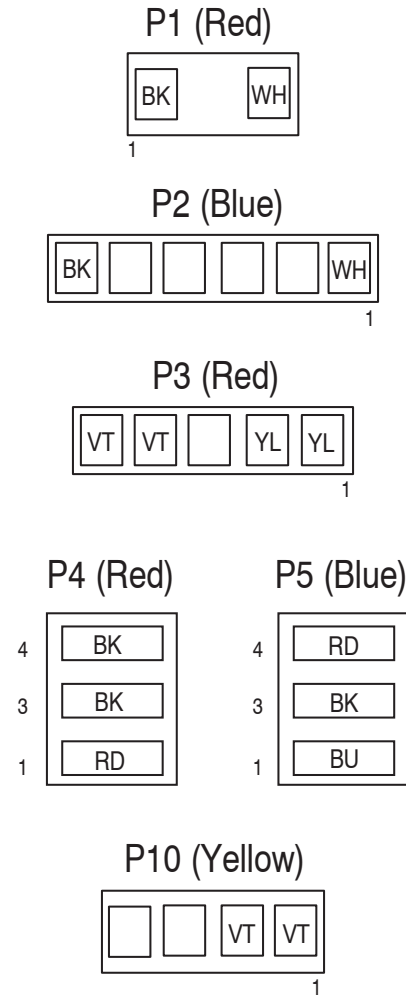

Oven Control Wiring Diagram

NOTE: Schematic shows oven door open and elements off.

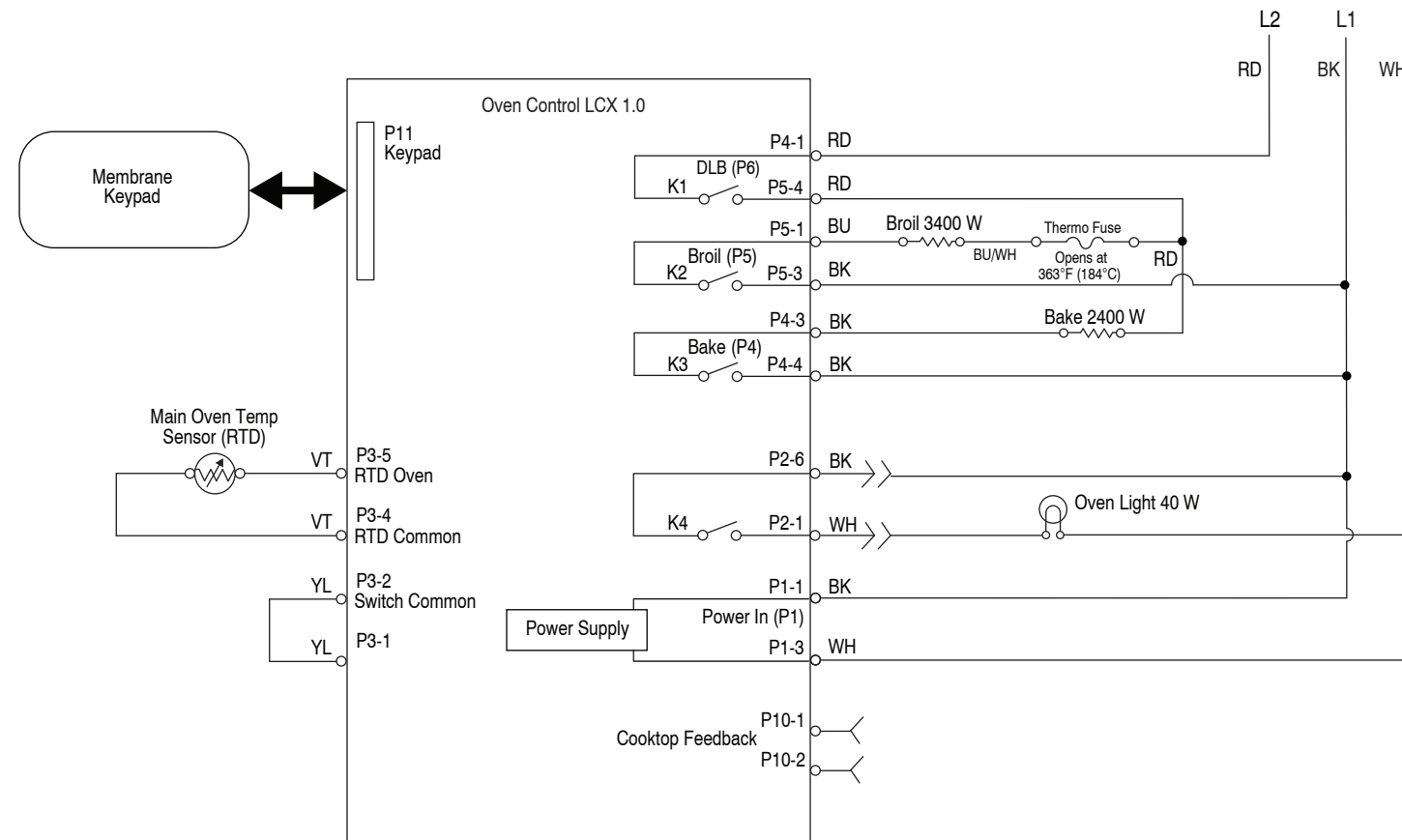

Cooktop Wiring Diagram

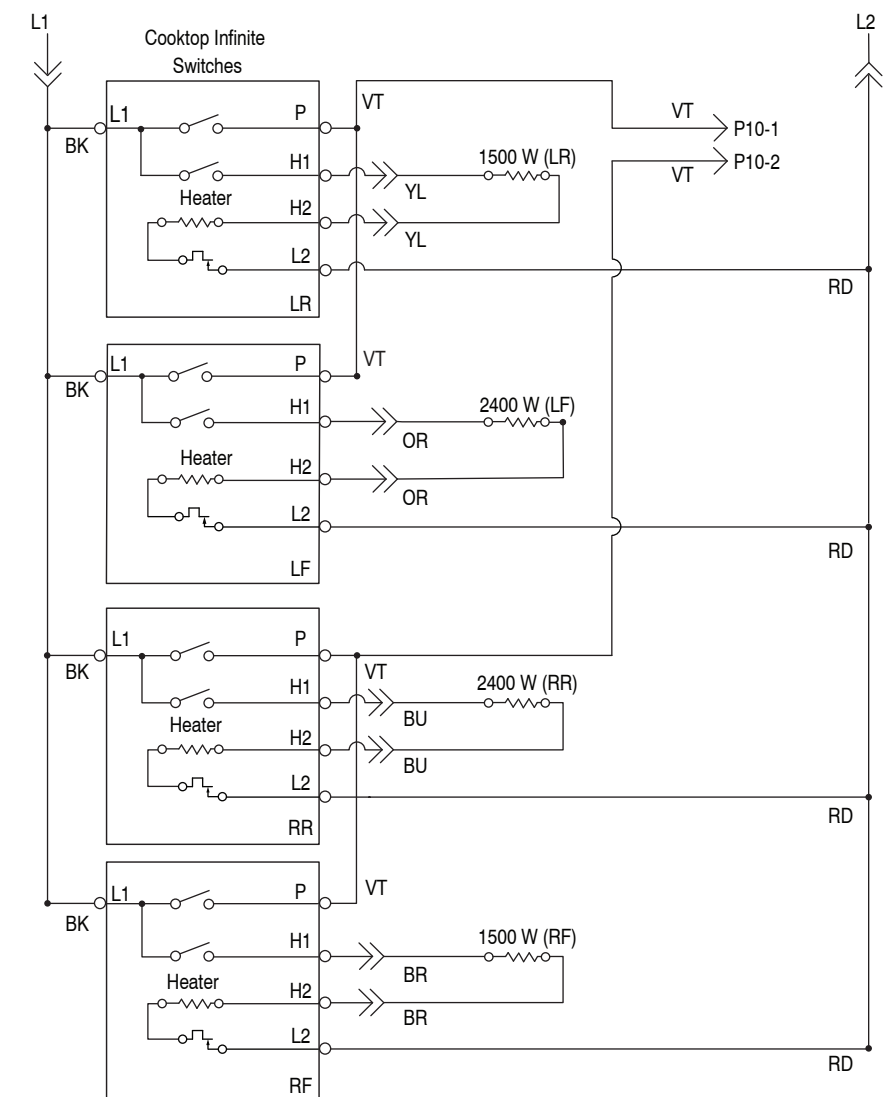

LEGEND

Connection	No Connection	On Some Models	In-Line Connection	Connector P2, Position 1	Circuitry Enclosed Within	Terminals	Single Switch	Thermal Switch (opens on heat rise)	Thermal Switch (closes on heat rise)	Resistor or Element	Motor	Incandescent Light	Non-resettable Fuse	Thermistor	Indicator Light	Triac	Thermo Fuse

À L'USAGE DU TECHNICIEN DE MAINTENANCE SEULEMENT

Schéma de câblage

Ne pas enlever ou détruire

Fiches à connexion rapide

Pour les commandes du four



Schéma de câblage du module de commande du four

REMARQUE : Le schéma montre la porte du four ouverte et les éléments éteints.



Schéma de câblage de la table de cuisson

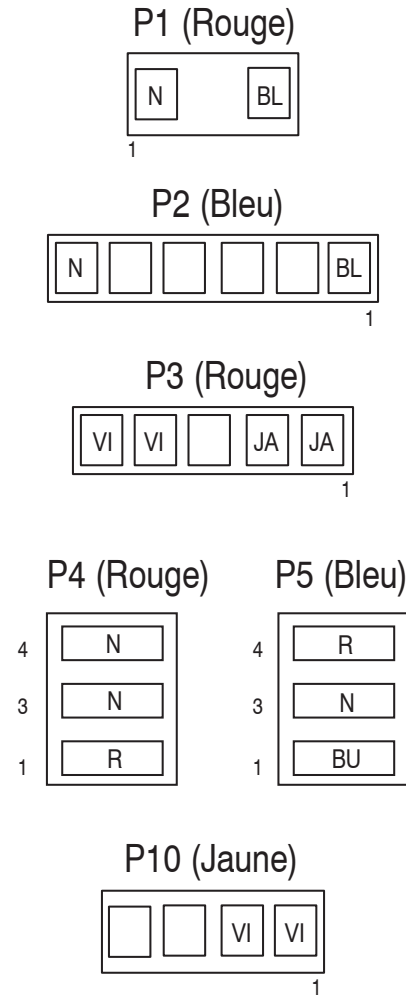

LÉGENDE

Connexion	Pas de connexion	Sur certains modèles	Connexion en série	Connecteur P2, position 1	Circuit à l'intérieur	Broches du composant	Contacteur simple	Commutateur thermique (s'ouvre lorsque la chaleur augmente)	Commutateur thermique (se ferme lorsque la chaleur augmente)	Résistance ou élément	Moteur	Lampe à incandescence	Fusible non réarmable	Thermistance	Témoin lumineux	Triac	Fusible thermique

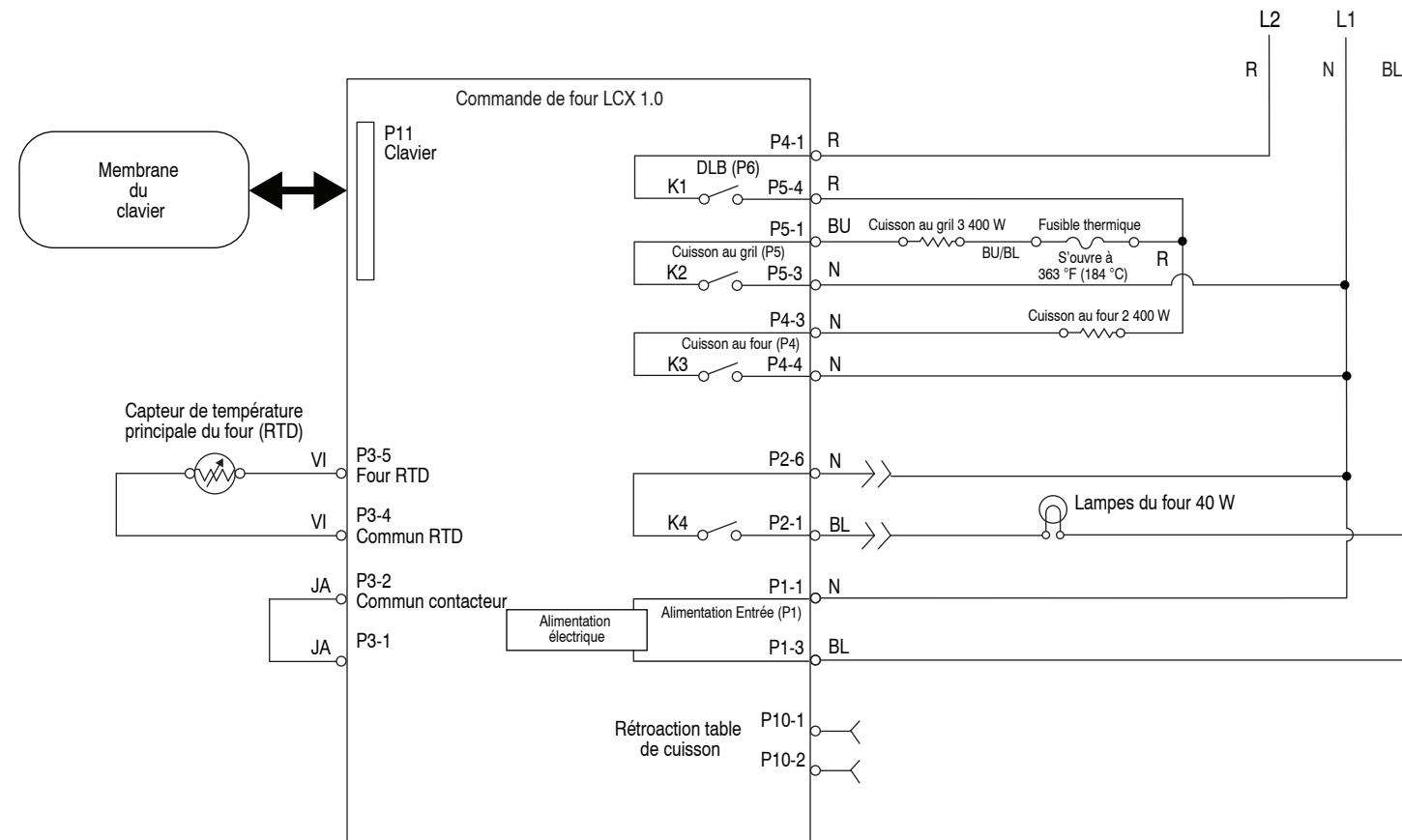
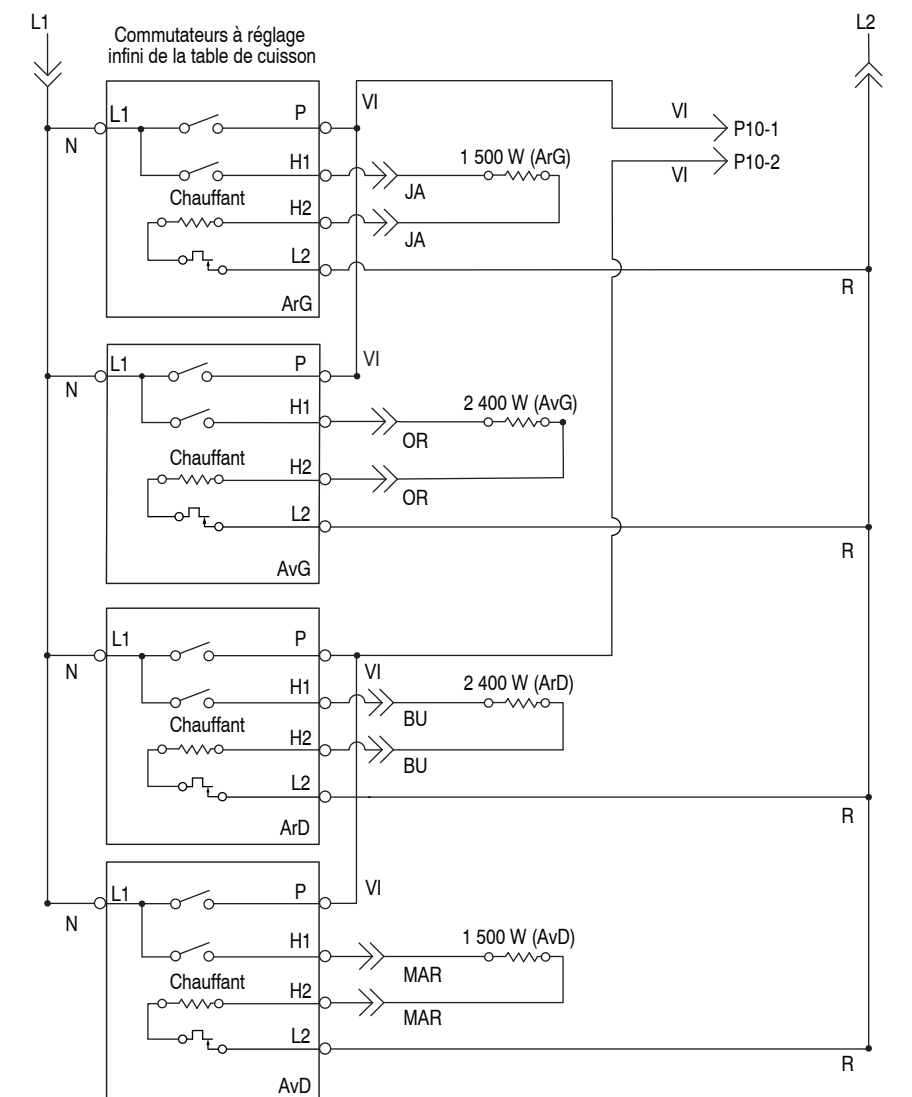
PARA SER USADO ÚNICAMENTE POR TÉCNICOS DE SERVICIO

Diagrama de cableado

No Quitar Ni Destruir

Enchufes de conexión rápida

Para controles del horno



Diagrama de cableado de control del horno

NOTA: El diagrama esquemático muestra la puerta del horno abierta y los elementos apagados.



Diagrama de cableado de superficie de cocción

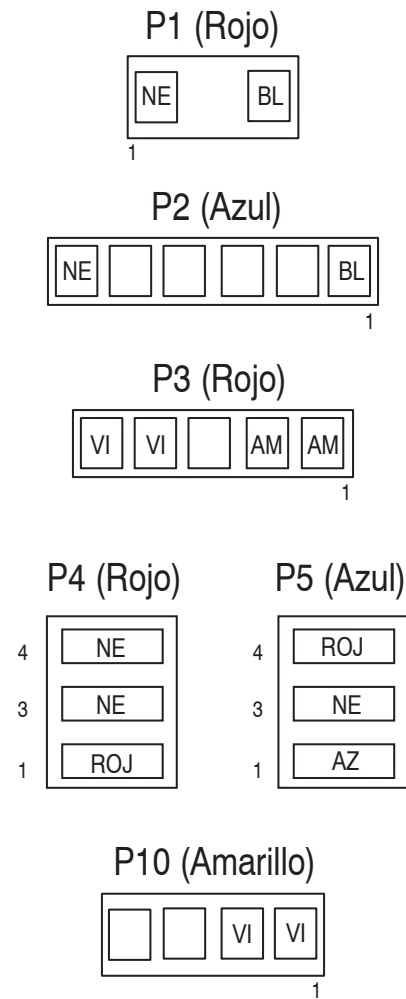
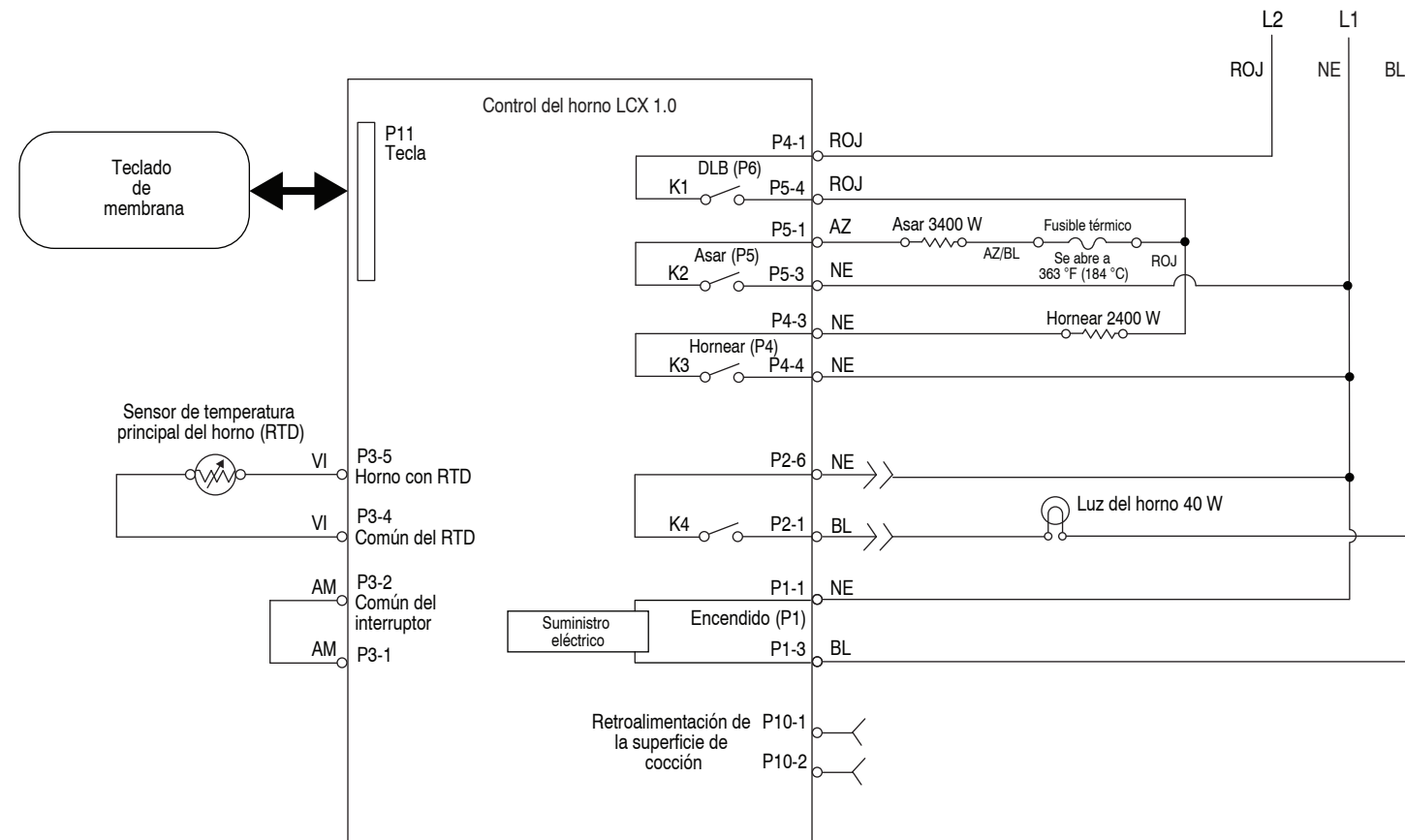
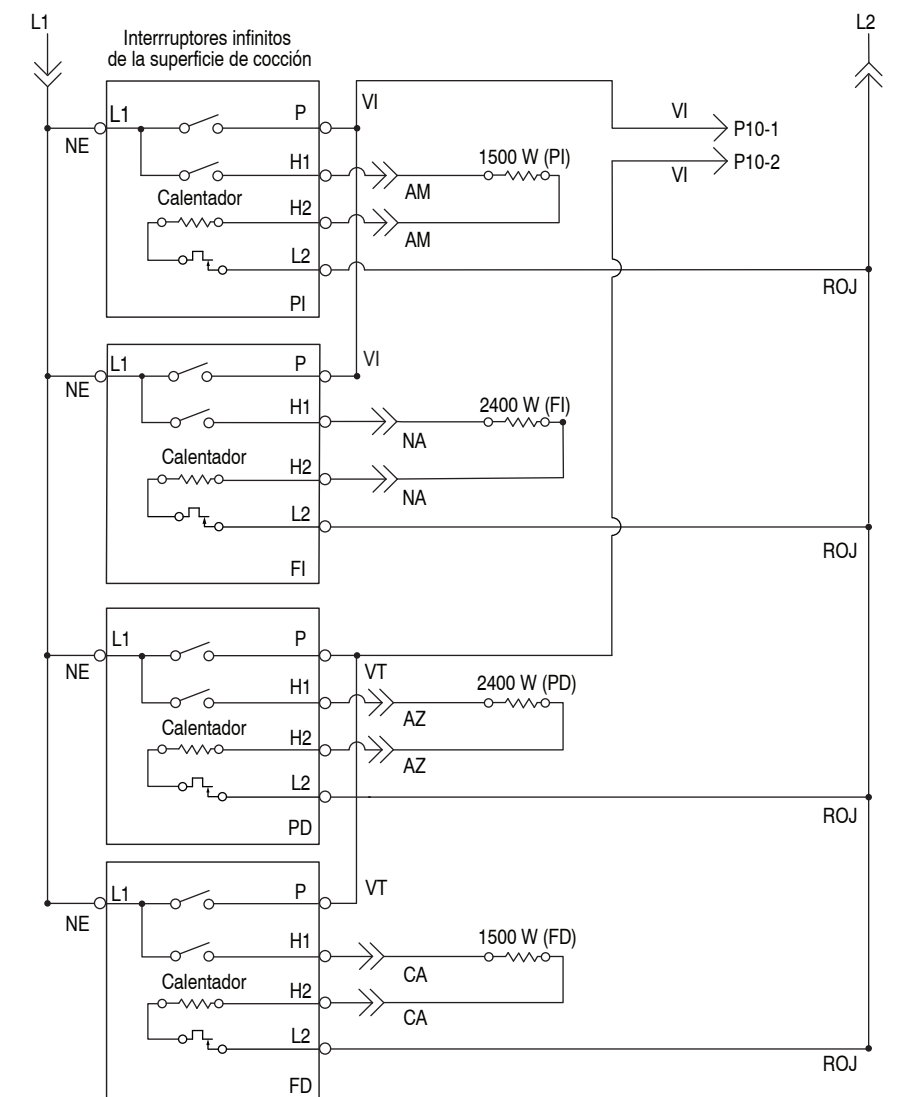

LEYENDA

Conexión	No hay conexión	En algunos modelos	Conexión en línea	Conector P2, Posición 1	Circuito cerrado	Terminales	Interruptor simple	Interruptor térmico (se abre con un alza de calor)	Interruptor térmico (se cierra con un alza de calor)	Resistor o Elemento	Motor	Luz incandescente	Fusible no reajustable	Termistor	Luz indicadora	Triac	Fusible térmico