

Whirlpool® MICROWAVE HOOD INSTALLATION INSTRUCTIONS

PRODUCT MODEL NUMBERS

WMH31017H

LOCATION REQUIREMENTS

Installation Dimensions

NOTE: The grounded 3 prong outlet must be inside the upper cabinet. See the "Electrical Requirements" section.

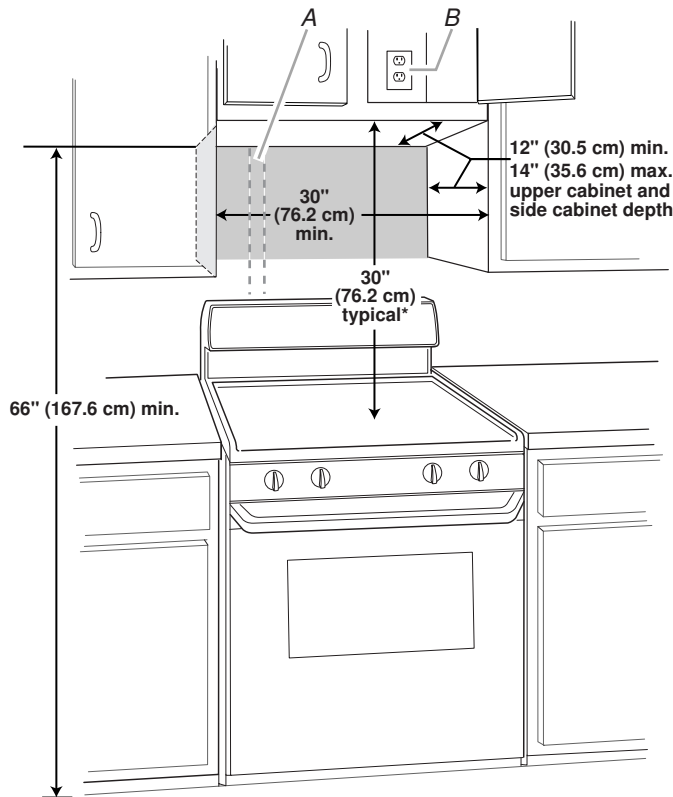

A. 2" x 4" wall stud
B. Grounded 3 prong outlet

*30" (76.2 cm) is typical for 66" (167.6 cm) installation height. Exact dimensions may vary depending on type of range/cooktop below.

PRODUCT DIMENSIONS

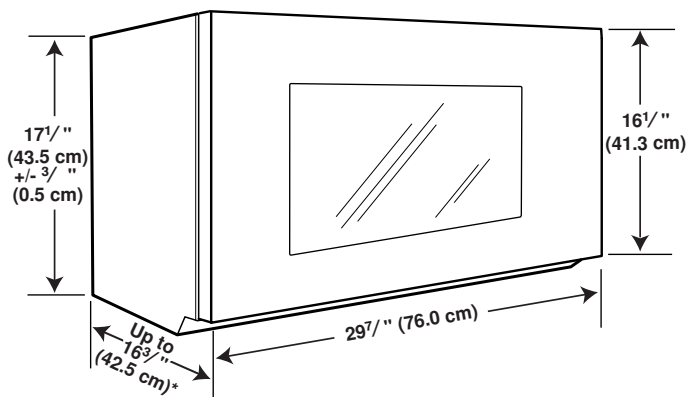

*Overall depth of product will vary slightly depending on door design.

PRODUCT DIMENSIONS

ELECTRICAL REQUIREMENTS

⚠ WARNING



Electrical Shock Hazard

- Plug into a grounded 3 prong outlet.
- Do not remove ground prong.
- Do not use an adapter.
- Do not use an extension cord.
- Failure to follow these instructions can result in death, fire, or electrical shock.

Observe all governing codes and ordinances.

Required:

A 120-volt, 60 Hz, AC-only, 15- or 20-amp electrical supply with a fuse or circuit breaker

Recommended:

- A time-delay fuse or time-delay circuit breaker
- A separate circuit serving only this microwave oven

VENTING DESIGN SPECIFICATIONS

This section is intended for architectural designer and builder/ contractor reference only.

NOTES:

Vent materials needed for installation are not provided with microwave hood combination.

We do not recommend using a flexible metal vent.

To avoid possible product damage, be sure to vent air outside, unless using recirculation installation. Do not vent exhaust air into concealed spaces, such as spaces within walls or ceilings, attics, crawl spaces, or garages.

For optimal venting installation, we recommend:

Using roof or wall caps that have back draft dampers

Using a rigid metal vent

Using the most direct route by minimizing the length of the vent and number of elbows to provide efficient performance

Using uniformly sized vents

Using duct tape to seal all joints in the vent system

Using caulking compound to seal exterior wall or roof opening around cap

Not installing 2 elbows together for optimal hood performance

If venting through the wall, be sure that there is proper clearance within the wall for the damper to open fully.

If venting through the roof, and rectangular-to-round transition is used, be sure there are at least 3" (7.6 cm) of clearance between the top of the microwave oven and the transition piece. See "Rectangular-to-Round Transition" illustration.

Rectangular-to-Round Transition

NOTE: The minimum 3" (7.6 cm) clearance must exist between the top of the microwave oven and the rectangular to round transition piece so that the damper can open freely and fully.

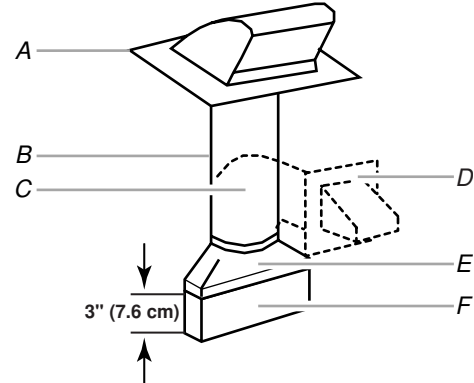

- A. Roof cap
- B. 6" (15.2 cm) min. diameter round vent
- C. Elbow (for wall venting only)
- D. Wall cap
- E. 3 1/2" x 10" to 6" (8.3 x 25.4 cm to 15.2 cm) rectangular to round transition piece
- F. Vent extension piece, at least 3" (7.6 cm) high

Recommended Standard Fittings

The following length equivalents are for use when figuring vent length. See the examples in "Recommended Vent Length."

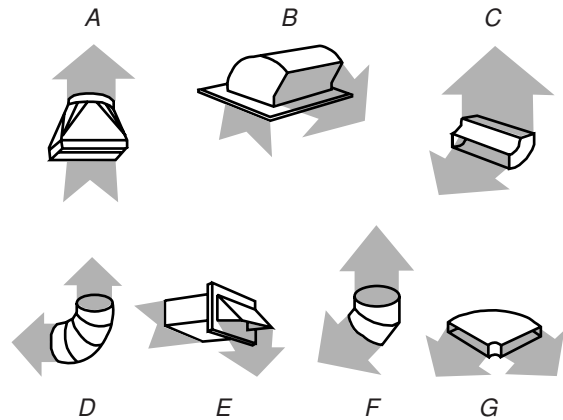

- A. Rectangular-to-round transition piece: 3 1/2" x 10" to 6" = 5 ft (8.3 x 25.4 cm to 15.2 cm = 1.5 m)
- B. Roof cap: 3 1/2" x 10" = 24 ft (8.3 x 25.4 cm = 7.3 m)
- C. 90° elbow: 3 1/2" x 10" = 25 ft (8.3 x 25.4 cm = 7.6 m)
- D. 90° elbow: 6" = 10 ft (15.2 cm = 3 m)
- E. Wall cap: 3 1/2" x 10" = 40 ft (8.3 x 25.4 cm = 12.2 m)
- F. 45° elbow: 6" = 5 ft (15.2 cm = 1.5 m)
- G. 90° at elbow: 3 1/2" x 10" = 10 ft (8.3 x 25.4 cm = 3 m)

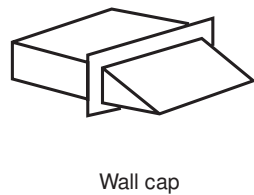
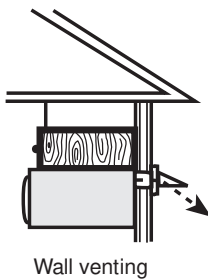
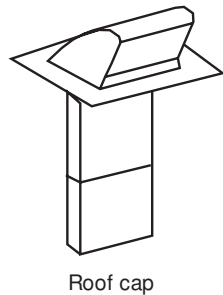
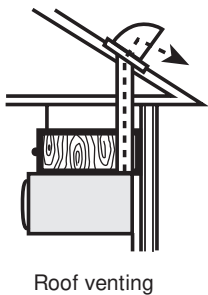

Recommended Vent Length

A 3¹/₂" x 10" (8.3 x 25.4 cm) rectangular or 6" (15.2 cm) round vent should be used.

The total length of the vent system including straight vent, elbow(s), transitions, and wall or roof caps must not exceed the equivalent of 140 ft (42.7 m) for either type of vent. See the "Recommended Standard Fittings" section for equivalent lengths.

For best performance, use no more than three 90° elbows.

To calculate the length of the system you need, add the equivalent lengths of each vent piece used in the system.

See the following examples:

3¹/₂" x 10" (8.3 x 25.4 cm) vent system = 73 ft (22.2 m) total

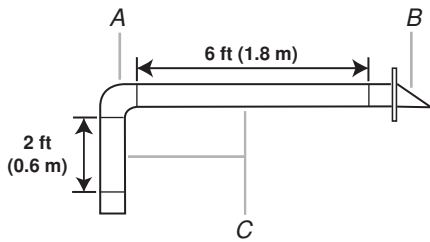

- A. One 3¹/₂" x 10" (8.3 x 25.4 cm) 90° elbow = 25 ft (7.6 m)
- B. 1 wall cap = 40 ft (12.2 m)
- C. 2 ft (0.6 m) + 6 ft (1.8 m) straight = 8 ft (2.4 m)

6" (15.2 cm) vent system = 73 ft (22.2 m) total

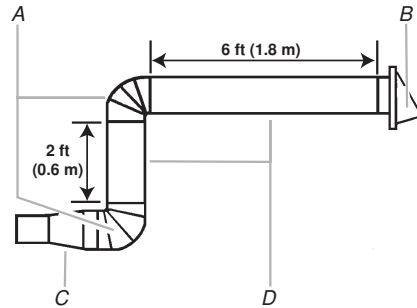

- A. Two 90° elbows = 20 ft (6.1 m)
- B. 1 wall cap = 40 ft (12.2 m)
- C. 1 rectangular-to-round transition piece = 5 ft (1.5 m)
- D. 2 ft (0.6 m) + 6 ft (1.8 m) straight = 8 ft (2.4 m)

If the existing vent is round, a rectangular-to-round transition piece must be used. In addition, a rectangular 3" (7.6 cm) extension vent between the damper assembly and rectangular-to-round transition piece must be installed to keep the damper from sticking.